

德士隆科技
源自意大利核心技术

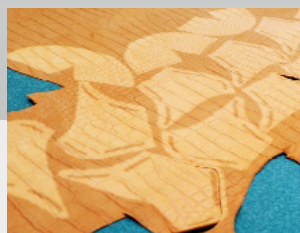

传输带式
Conveyor



裁切
Cutting



画线
Marking



冲孔
Punching



半皮
Half hide



小张皮
Small hide



双层切割
Double-layer
cutting

C-612S / **智能振动刀切割机**
Intelligent Cutting Machine

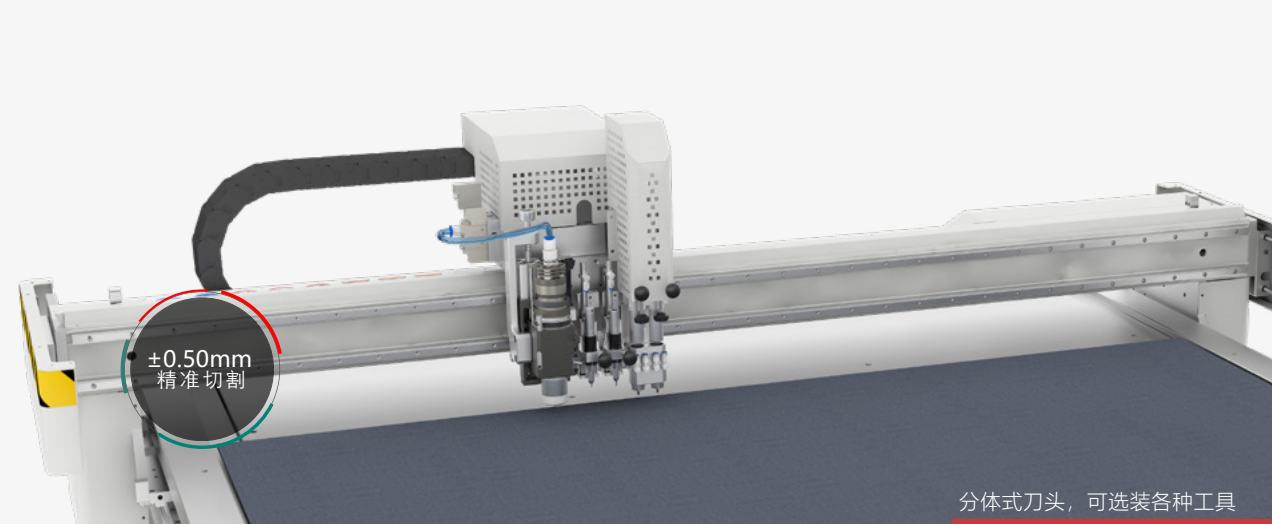

±0.50mm
精准切割

分体式刀头，可选装各种工具

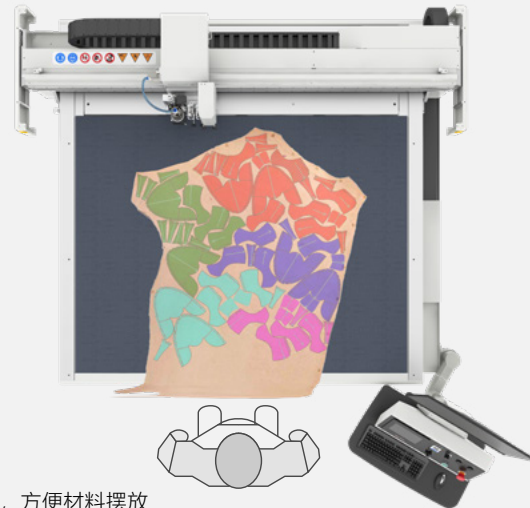

全尺寸切割区域，方便材料摆放

- **Small Machine Great Intelligence.**
Compact size with optional tool attachments.
- **Easy to Operate.**
Easy operation with multilingual support.
- **Core Components From Leading Brands.**
Ensuring long-lasting stability with genuine materials.
- **Precision Projection Layout.**
Fast and precise manual projection layout.
- **Wide Range of Applications.**
Footwear, luggage, sofa, and automotive industries.
- **High-precision Cutting.**
Industry-leading cutting precision of ± 0.5 mm.
- **Integrated Tool Head.**
Cutting, punching, and marking can be completed in a single process.
- **Unlimited Format.**
DXF file compatibility.
- **Silent Technology.**
Operating noise ≤ 80 dB.
- **Ultra Energy-saving.**
Intelligent variable-speed vacuum pump for energy savings.

高精度裁切

切割精度 0.50mm \pm 业内领先

集成工具刀头

切割、冲孔、画线一次完成

格式永久无锁

兼容性强，识别通用 DXF 文件格式

静音技术

工作噪音 ≤ 80 分贝

超省电

智能变速真空泵，节省能耗

小机器大智慧

体积小，可选装各种工具

简单易上手

操作简单，支持多国语言

品牌核心部件

以真材实料保障机器持久稳定

精准投影排版

投影手动排版快速精准

应用广泛

鞋、箱包、沙发、汽车行业

标配

Standard configuration



选配

Optional configuration



选配

Optional configuration



适用材料
皮革 / 海绵 / 中底板等

切割速度 Cutting Speed
1.3m/s

刀头振动频率 vib. freq.
15000RPM

噪音标准 Noise Standard
分贝 ≤ 80 dB

切割厚度
海绵材料 ≤ 20 mm
柔性材料 ≤ 15 mm
硬性材料 ≤ 8 mm

传动系统
高精度齿条 / 伺服电机

兼容格式 Compatible Formats
DXF/AI/PLT

切割工具
气动振动刀
打孔冲头
记号画笔
记号针

排版方式
手动排版

总功率 Total Power
12 kW

机器尺寸 Machine Size(长宽 LWH)
2200mm x 1700mm x 2000mm

切割区域 Working Range(长宽 LW)
1600mm x 1200mm

重量 Weight
920 Kg
机器电压 Voltage
AC 380V 50Hz